

Hiab XS 099

Range 7-10 tm



Hiab XS 099 Basic data

Technical data

	B-3 CL	B-2 Duo	B-3 Duo	E-4 HiDuo	E-5 HiDuo
Max. lifting capacity (kNm)	77	87	77	81	78
Outreach - hydraulic extensions (m)	9.8	7.8	9.8	12.1	14.3
Outreach - manual extensions (m)	11.9	9.8 - 11.9	11.6	14.1	-
Outreach / Lifting capacity, standard (m / kg)	3.0 / 2640	2.7 / 3250	3.0 / 2860	2.5 / 3650	2.6 / 3400
	4.2 / 1860	4.1 / 2160	4.2 / 2020	4.4 / 2060	4.5 / 1920
	5.8 / 1300	5.7 / 1540	5.8 / 1420	6.0 / 1420	6.1 / 1300
	7.6 / 960	7.6 / 1140	7.6 / 1060	7.9 / 1020	8.0 / 920
	9.5 / 760	-	9.5 / 840	9.9 / 780	10.0 / 680
	-	-	-	12.0 / 640	12.1 / 540
	-	-	-	-	14.2 / 450
Slewing angle	406°	406°	406°	406°	406°
Height in folded position (mm)	2100	2100	2100	2100	2100
Width in folded position (mm)	2300	2300	2280	2300	2400
Installation space needed (mm)	770	690	770	725	835
Weight - "standard" crane without stabilizers (kg)	1230	1140	1230	1480	1580
Weight - stabilizer equipment (kg)	135 - 205	135 - 205	140 - 285	140 - 285	140 - 285

Hiab XS 099 E-5 HiDuo

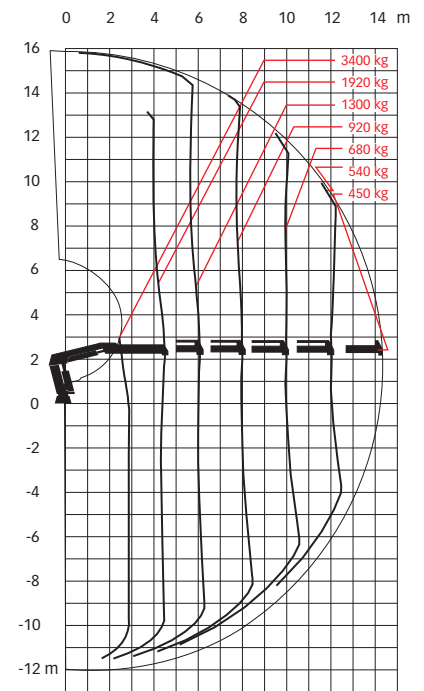
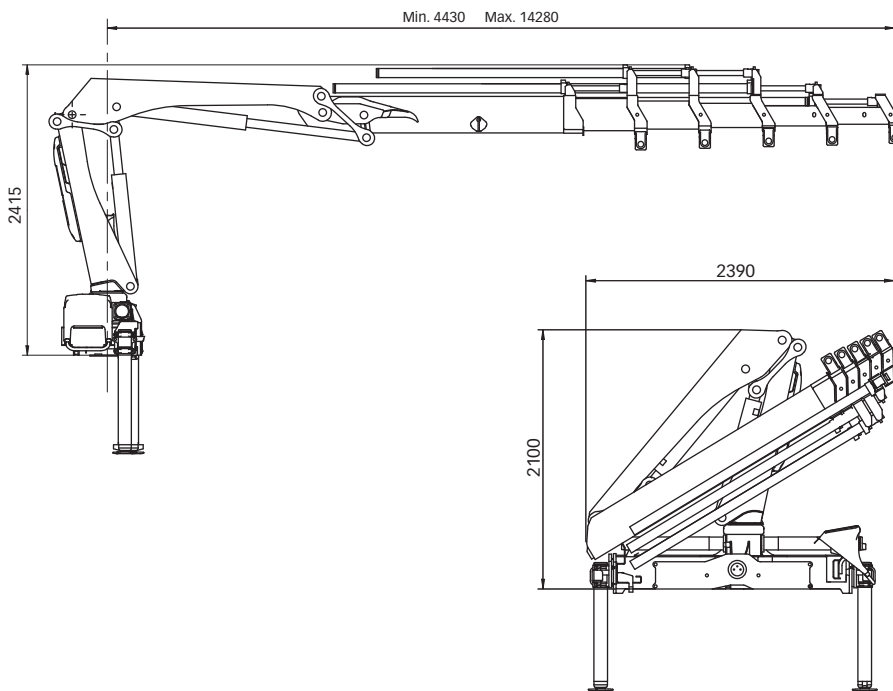

Disclaimer. Hiab cranes have been built to meet the highest standards of safety and service life and have been thoroughly tested. Strength calculations for this model have been carried out in accordance with EN13001 in fatigue class S2. Cargotec's certified Quality Assurance System complies with ISO 9001. Some of the items in our literature may be extra equipment. Certain applications may require an official permit. We reserve the right to change technical specifications without prior notice. Hiab cranes produced for EU-countries are CE-marked and comply with the European Standard EN 12999.

Cargotec improves the efficiency of cargo flows by offering solutions for the loading and unloading of goods on land and at sea – wherever cargo is on the move. Cargotec's main daughter brands for cargo handling Hiab, Kalmar and MacGregor are global market leaders in their fields. www.cargotec.com